

Angle Seat Globe Valve, Metal Aseptic

Construction

The GEMÜ 505 manually operated 2/2-way valve has a high temperature rated plastic handwheel and is designed for pure steam applications. The valve has a PTFE seat for tight shut off and the valve spindle is sealed by a stainless steel bellows.

Features

- Suitable for pure steam and gaseous media
- For materials and connections see the following pages
- Internal surface of valve body $\leq Ra\ 0.4\ \mu m$, external surface electro-polished

Options

- Versions according to ATEX on request

Advantages

- Free from non-ferrous metals
- Stainless steel bellows seal
- Welded valve plug
- Low maintenance fixed seat plug (without threads)
- Fast operator change possible
- Optical position indicator integrated as standard
- Traceability of all wetted parts
- Suitable for contact with food according to Regulation (EC) No. 1935/2004 (K-No. 1935)

Sectional drawing

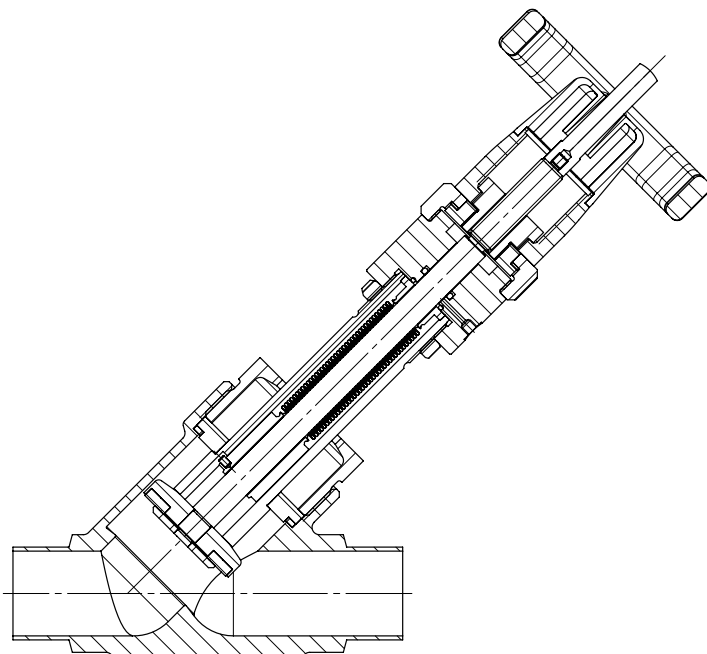

Order data

Body configuration	Code
2/2-way body	D

Flow direction	Code
Under the seat	G
Over the seat (up to DN 50)	M

Connection	Code
Butt weld spigots	
Spigots DIN 11866, series A	1A
Spigots DIN 11866, series B	1B
Spigots ASME BPE	59
Clamp connections	
Clamps DIN 32676 series B for pipe EN ISO 1127, length EN 558, series 1	82
Clamps DIN 32676 series A for pipe DIN 11850, length EN 558, series 1	86
Clamps ASME BPE for pipe ASME BPE, length EN 558, series 1	88

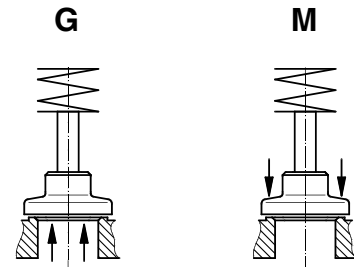

Valve body material	Code
1.4435 (316 L), block material	41
1.4435, investment casting	C2*

* A surface finish from the order code table "Special version" must be specified for valve body material C2.

Seat seal	Code
PTFE	5P

Control function	Code
Manually operated	0

Bonnet size	Code
DN 8 - 20	1
DN 25 - 32	2
DN 40 - 80	3

Handwheel material	Code
Plastic	P

K number	Code
Surface finish for valve body material C2	
external surface electrolytically gloss polished / mechanically polished internal Ra ≤ 0.6 µm	1903
external surface electrolytically gloss polished / mechanically polished internal Ra ≤ 0.8 µm	1904
external surface electrolytically gloss polished / mechanically polished internal Ra ≤ 0.4 µm	1909

Special version	Code
Stainless steel bellows seal	F

Order example	505	25	D	1A	C2	5P	0	2	G	P	1903	F
Type	505											
Nominal size		25										
Body configuration (code)			D									
Connection (code)				1A								
Valve body material (code)					C2							
Seat seal (code)						5P						
Control function (code)							0					
Bonnet size (code)								2				
Flow direction (code)									G			
Handwheel material (code)										P		
K number (code)											1903	
Special version (code)												F

Body dimensions [mm]

Butt weld spigots, connection code 1A, 1B, 59 Valve body material: 1.4435 (code 41, C2)

			Connection code					
			1A		1B		59	
DN	L	LB	ø d	s	ø d	s	ø d	s
8	105*	35.5*	10	1.0	13.5	1.6	-	-
10	105	35.5	13	1.5	17.2	1.6	-	-
15	105	35.5	19	1.5	21.3	1.6	12.70	1.65
20	120	39.0	23	1.5	26.9	1.6	19.05	1.65
25	125	39.5	29	1.5	33.7	2.0	25.40	1.65
32	155	48.0	35	1.5	42.4	2.0	-	-
40	160	47.0	41	1.5	48.3	2.0	38.10	1.65
50	180	48.0	53	1.5	60.3	2.0	50.80	1.65
65	290	96.0	70	2.0	76.1	2.0	63.50	1.65
80	310	95.0	85	2.0	88.9	2.3	76.20	1.65

* Connection code 1A: L = 100, LB = 33.5

For materials see overview on page 5

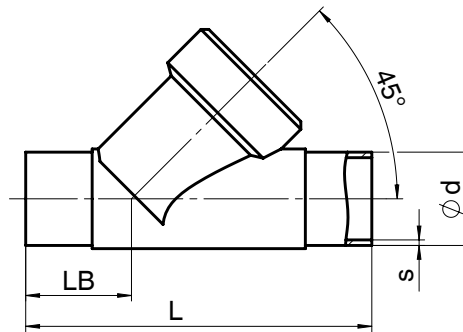

Clamp connections, connection code 82, 86, 88 Valve body material: 1.4435 (code C2)

DN		NPS		Connection code							
				LB	L	82		86		88	
						ø d1	ø d3	ø d1	ø d3	ø d1	ø d3
15	1/2"	47.5	130	18.1	50.5	16	34.0	9.40	25.0		
20	3/4"	54.0	150	23.7	50.5	20	34.0	15.75	25.0		
25	1"	56.0	160	29.7	50.5	26	50.5	22.10	50.5		
32	1 1/4"	60.5	180	38.4	64.0	32	50.5	-	-		
40	1 1/2"	67.0	200	44.3	64.0	38	50.5	34.80	50.5		
50	2"	73.0	230	56.3	77.5	50	64.0	47.50	64.0		
65	2 1/2"	120.0	290	72.1	91.0	66	91.0	60.2	77.5		
80	3	119.0	310	84.3	106.0	81	106.0	72.9	91.0		

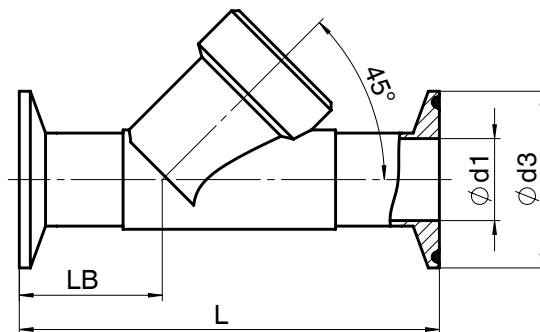

Overview of metal bodies for GEMÜ 505

Connection code	Spigots					Clamps		
	1A		1B	59		82	86	88
Material code	C2	41	C2	C2	41	C2	C2	C2
DN 8	-	X	X	-	X	-	-	-
DN 10	X	-	X	-	X	-	-	-
DN 15	X	-	X	X	-	X	X	X
DN 20	X	-	X	X	-	X	X	X
DN 25	X	-	X	X	-	X	X	X
DN 32	X	-	X	-	-	X	X	-
DN 40	X	-	X	X	-	X	X	X
DN 50	X	-	X	X	-	X	X	X
DN 65	X	-	X	X	-	X	X	X
DN 80	X	-	X	X	-	X	X	X

Pneumatic angle seat globe valve in Aseptic design



GEMÜ 555

For further globe valves, accessories and other products, please see our Product Range catalogue and Price List.
Contact GEMÜ.

GEMÜ® VALVES, MEASUREMENT
AND CONTROL SYSTEMS

