

Motorized Quarter Turn Actuator

Construction

The powerful GEMÜ 9468 motorized quarter turn actuator is a very compact design where the motor and gear are combined as one unit. It is designed for use with AC or DC voltages and utilises a DC motor with a secondary planetary gear/toothed belt drive. The 90° movement is achieved by a lever mounted to a ball running on a threaded spindle. This operates similar to the scotch-yoke principle. A manual override and an optical position indicator are standard. The housing is made of aluminium or plastic.

Features

- Maintenance-low actuator
- Optical position indicator
- Quiet operation
- Optional mounting position
- Manual override
- Protection class IP 65
- Adjustable limit switches

Advantages

- Low weight
- Optical position indicator as standard
- Integrated manual override
- Optional accessories
 - Additional adjustable limit switches for potential-free control signals
 - Integrated positioner 4-20 mA
 - Analogue position feedback by potentiometer



Actuator version code 2070



Actuator version code 4100 /4200



Actuator version code 6400

Dimensions [mm]

Actuator version code 2070

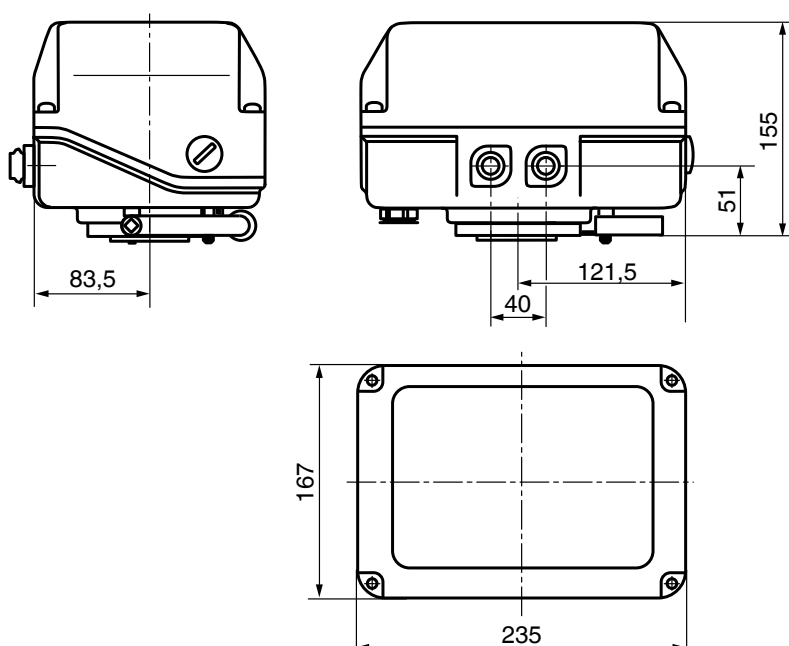

Dimensions of actuator versions code 4100, 4200 and 6400 see page 4.

Technical data

Directives

EC Machine directive 2006/42/EG, annex II B
EG-EMV-Richtlinie 89/336/EWG

Actuator material

Actuator version 2070 ABS
Actuator version 4100/4200/6400 Aluminium

Housing protection class to EN 60529

IP 65

Turn range

Nominal turn range 90°
Max. turn range 93°
Setting range limit switch min. 0-20°
Setting range limit switch max. 70-93°

Admissible temperatures

Ambient temperature -10 to +60° C
Storage temperature -20 to +60° C

Torque

Actuator version 2070 70 Nm
Actuator version 4100 100 Nm
Actuator version 4200 200 Nm
Actuator version 6400 400 Nm

Weight

Actuator version 2070 4.6 kg
Actuator version 4100/4200 11 kg
Actuator version 6400 14 kg

Mounting position

Optional

Operating time

Actuator version 2070 approx. 15 sec
Actuator version 4100 approx. 20 sec
Actuator version 4200 approx. 16 sec
Actuator version 6400 approx. 29 sec

Manual override

with enclosed winch

Coordination / availability

Actuator version (Code)	Flange type (Code)		Supply voltage / mains frequency							
			24 V DC (Code C1)		24 V AC (Code C4)		120 V AC (Code G4)		230 V AC (Code L4)	
	F07	F10	Functional module (Code)							
	Schlüsselweite		A0/AE/AP E1/E2	00/0E/0P	A0/AE/AP E1/E2	00/0E/0P	A0/AE/AP E1/E2	00/0E/0P	A0/AE/AP E1/E2	00/0E/0P
2070	S11/S14/S17	-	X	X	-	X	X	-	X	-
4100	-	S14/S17	X	X	-	X	X	X	X	X
4200	-	S17/S22	X	X	-	X	X	X	X	X
6400	-	S22	X	X	-	X	X	X	X	X

Technical data

Power supply

Rated voltage	24 V DC / 24 V, 120 V, 230 V AC
Rated frequency at AC rated voltage	50/60 Hz
Voltage tolerance	+10% / -15%

Output signals (option)

Actual value potentiometer	3 k Ω (± 20 %)
Potential-free limit switches change-over contact	250 V AC/6A

Power and current consumption

Actuator version code	24 V DC		24 V AC		120 V AC		230 V AC	
	A0/AE/AP E1/E2	00/0E/0P	A0/AE/AP E1/E2	00/0E/0P	A0/AE/AP E1/E2	00/0E/0P	A0/AE/AP E1/E2	00/0E/0P
Power consumption [W]								
2070	96	63	-	63	160	-	161	-
4100	96	105	-	140	160	105	161	130
4200	96	90	-	110	160	90	161	105
6400	120	120	-	120	170	120	185	145
Current consumption - Rated current [A]								
2070	4	2.6	-	2.6	1.2	-	0.7	-
4100	4	4.4	-	5.8	1.2	0.88	0.7	0.55
4200	4	3.6	-	4.5	1.2	0.72	0.7	0.45
6400	5	5.0	-	6.3	1.4	1.00	0.8	0.63
Current consumption - Max. current at start up [A]								
2070	4	14	-	34	1.2	-	0.7	-
4100	4	35	-	35	1.2	16	0.7	1
4200	4	35	-	35	1.2	16	0.7	1
6400	5	35	-	35	1.4	16	0.8	1

Rating

Actuator version 2070/4100/4200	100% rating
Actuator version 6400	70% rating

Input signals

0-10V ($R_i = 45$ k Ω) with functional module E1	
4-20 mA ($R_i = 33$ Ω) with functional module E2	
Switching input OPEN/CLOSE for A0/AE/AP	24V - 250V DC/AC
Switching input OPEN/CLOSE for 00/0E/0P	24V DC / 24V AC / 120V AC / 230V AC*
* depending on rated voltage	

Electrical connection

Plug type	Flange plug Binder series 692/693
Cable diameter	max. 8 mm
Max. cross section of wire	0.75 mm ²

Electrical protection class

I

Internal overload protection with functional module 0x

Actuator version	Supply voltage	Protection value/A
2070	24 V DC	MT 6.3
4100-6400	24 V DC	MT 10
4100-6400	24 V AC	MT 10
4100-6400	120 V AC	MT 1.6
4100-6400	230 V AC	MT 1.0

Recommended motor protection

Voltage	Motor protection switch	Set current
24V DC	Siemens 3RV 1011-1FA10	4.0 A
24V AC	Siemens 3RV 1011-1FA10	4.0 A
120V AC	Siemens 3RV 1011-OHA10	0.6 A
230V AC	Siemens 3RV 1011-OHA10	0.6 A

Order data

Fieldbus	Code
Without	000

Accessory	Code
Accessory	Z

Connection version	Code
Flange type F05 + F07	F07
Flange type F07 + F10	F10

Location spigot	Code
Actuator with location spigot	Y
Actuator without location spigot (only for actuator version 2070)	N

Square	Code
SW 11	S11
SW 14	S14
SW 17	S17
SW 22	S22

Supply voltage / mains frequency	Code
24 V DC	C1
24 V AC 50/60 Hz	C4
120 V AC 50/60 Hz	G4
230 V AC 50/60 Hz	L4

Functional module	Code
OPEN/CLOSE control with relay, not reversible	00*
OPEN/CLOSE control with 2 additional potential-free limit switches, with relay, not reversible	0E*
OPEN/CLOSE control with potentiometer output, with relay, not reversible	0P*
OPEN/CLOSE control	A0**
OPEN/CLOSE control with 2 additional potential-free limit switches	AE**
OPEN/CLOSE control with potentiometer output	AP**
Control module; for external set value 0-10 V DC	E1**
Control module; for external set value 4-20 mA	E2**

* Overall height 1

** Overall height 2

Actuator version	Code
70 Nm	2070
100 Nm	4100
200 Nm	4200
400 Nm	6400

Order example	9468	000	Z	F10	Y	S17	C1	00	4100
Type	9468	000	Z	F10	Y	S17	C1	00	4100
Connection size (code)			Z	F10					
Location spigot (code)					Y				
Square (code)						S17			
Supply voltage / mains frequency (code)							C1		
Functional module (code)								00	
Actuator version (code)									4100

Dimensions [mm]

Actuator version code 4100, 4200

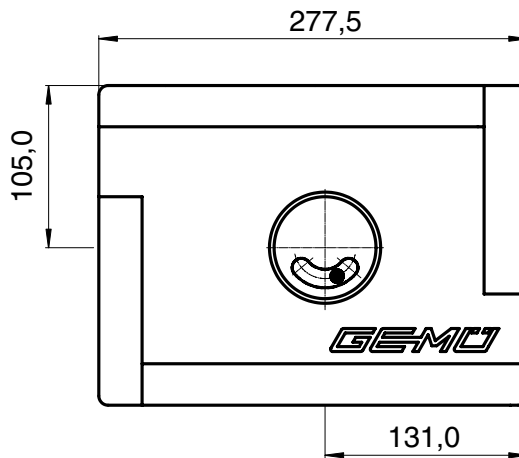
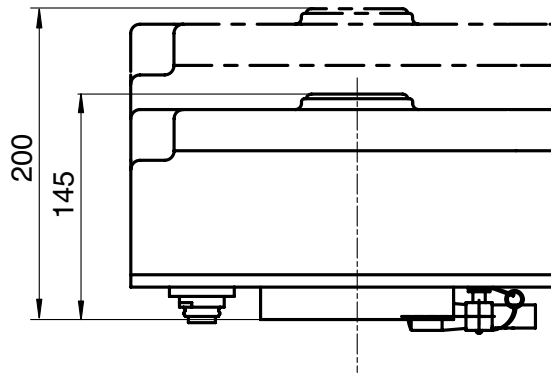
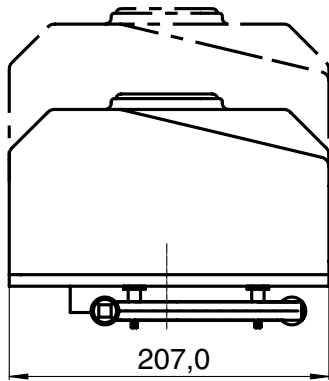

- full line
- △ overall height 1 version functional module code 00, 0E, 0P
- - - - broken line
- △ overall height 2 version functional module code A0, AE, AP, E2, E1

Actuator version code 6400

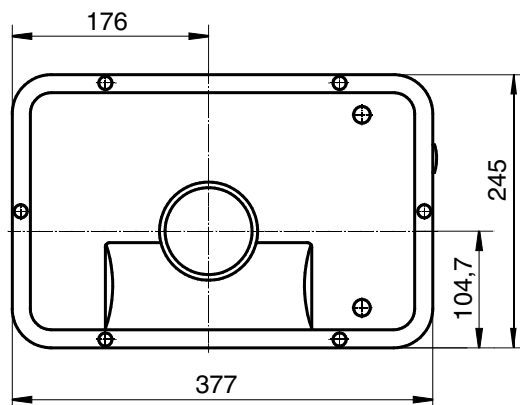
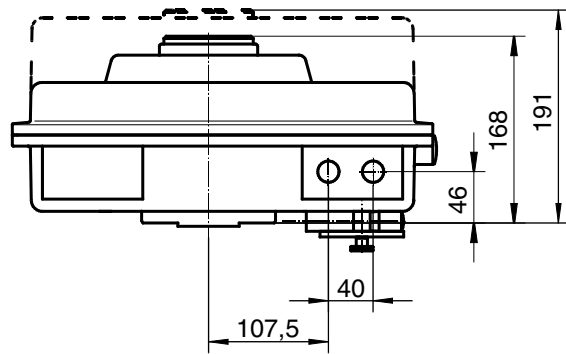
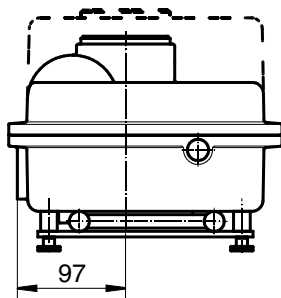

- full line
- △ overall height 1 version functional module code 00, 0E, 0P
- - - - broken line
- △ overall height 2 version functional module code A0, AE, AP, E2, E1

Mounting dimensions [mm]

DIN ISO 5211

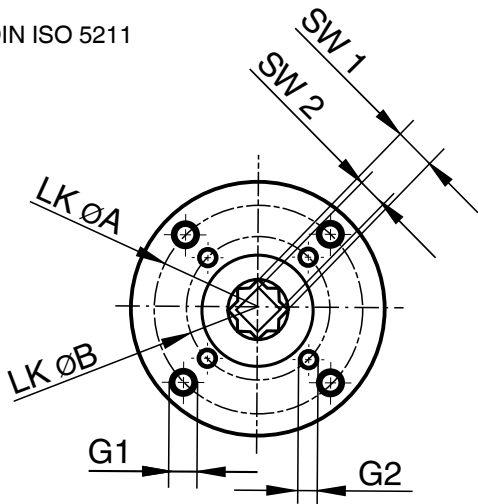

Actuator version (Code)	Connection version (Code)	includes flange type	LK øA	LK øB	G1	G2	SW1	SW2*	SW3*
2070	F07	F05 / F07	70	50	M8	M6	17	14	11
4100	F07	F07 / F10	102	70	M10	M8	17	14	-
4200	F07	F07 / F10	102	70	M10	M8	22	17	-
6400	F10	F07 / F10	102	70	M10	M8	22	-	-

*Squareadapter

Connection / wiring diagram [mm]

OPEN / CLOSE version (Code A0)

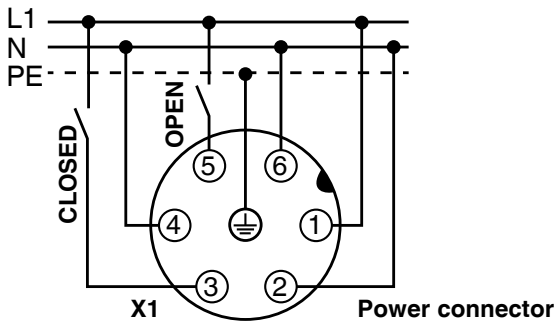

Pin	Signal name
1	L1 / L+, Supply voltage
2	N1 / L-, Supply voltage
3	L1 / L+, Direction of travel CLOSE
4	N / L-, Direction of travel CLOSE
5	L1 / L+, Direction of travel OPEN
6	N / L-, Direction of travel OPEN
⊕	PE, Protective earth conductor

When the OPEN and CLOSE switches are operated simultaneously the actuator "CLOSES".

In the connector plug pins 2, 4 and 6 can be connected.

→ Advantage: 5-wire cable can be used.

No galvanic separation of inputs!

2 potential-free limit switches (Code AE)

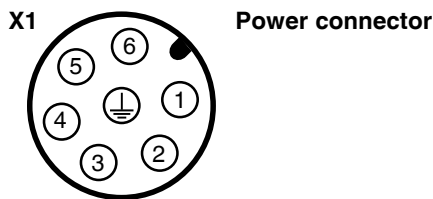

Pin	Signal name
1	L1 / L+, Supply voltage
2	N1 / L-, Supply voltage
3	L1 / L+, Direction of travel CLOSE
4	N / L-, Direction of travel CLOSE
5	L1 / L+, Direction of travel OPEN
6	N / L-, Direction of travel OPEN
⊕	PE, Protective earth conductor

N/L signals in the unit are separated.

Potential assignment by customer.

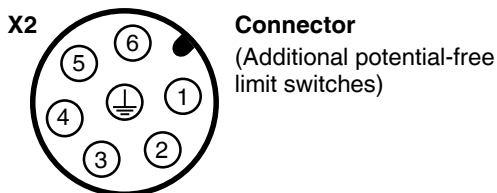

Pin	Signal name
1	S 1:1, Change-over contact limit switch CLOSE
2	S 1:4, Make-contact limit switch CLOSE
3	S 1:2, Break-contact limit switch CLOSE
4	S 2:2, Break-contact limit switch OPEN
5	S 2:4, Make-contact limit switch OPEN
6	S 2:1, Change-over contact limit switch OPEN
⊕	PE, Protective earth conductor

When the OPEN / CLOSE switches are operated simultaneously the actuator "CLOSES".

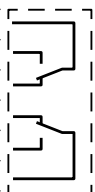

Potentiometer output (Code AP)

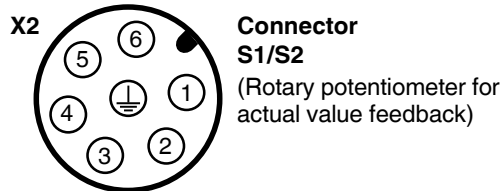
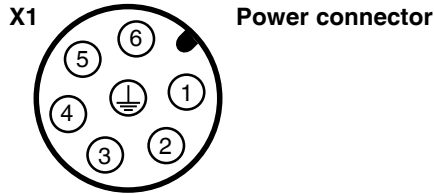

When the OPEN / CLOSE switches are operated simultaneously the actuator "CLOSES".

Pin	Signal name
1	L1 / L+, Supply voltage
2	N1 / L-, Supply voltage
3	L1 / L+, Direction of travel CLOSE
4	N / L-, Direction of travel CLOSE
5	L1 / L+, Direction of travel OPEN
6	N / L-, Direction of travel OPEN
Ⓧ	PE, Protective earth conductor

N/L signals in the unit are separated.
Potential assignment by customer.

Pin	Signal name
1	n.c.
2	n.c.
3	n.c.
4	Us-, Actual value potentiometer signal voltage minus
5	Us _o , Actual value potentiometer signal output
6	Us+, Actual value potentiometer signal voltage plus
Ⓧ	PE, Protective earth conductor

Control module (Code E2)

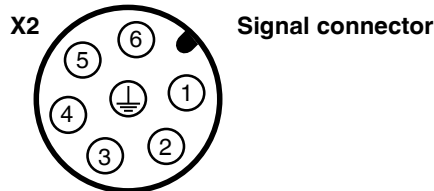
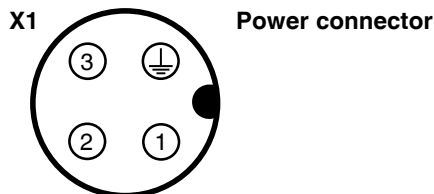

Pin	Signal name
1	L1 / L+, Supply voltage
2	N1 / L-, Supply voltage
3	n.c.
Ⓧ	PE, Protective earth conductor

Pin	Signal name
1	n.a. (do not use)
2	n.a. (do not use)
3	I-, external set value 4-20 mA
4	I+, external set value 4-20 mA
5	n.c.
6	n.c.
Ⓧ	PE, Protective earth conductor

Note: Set value and supply voltage must be galvanically isolated.

Control module (Code E1)

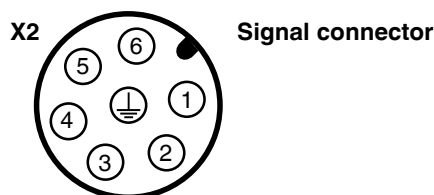
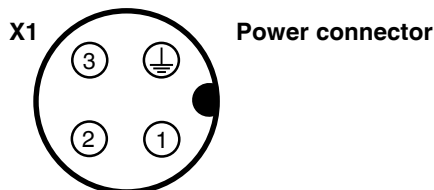

Pin	Signal name
1	L1 / L+, Supply voltage
2	N1 / L-, Supply voltage
3	n.c.
Ⓧ	PE, Protective earth conductor

Pin	Signal name
1	n.a. (do not use)
2	n.a. (do not use)
3	U-, external set value 0-10 V
4	U+, external set value 0-10 V
5	n.c.
6	n.c.
Ⓧ	PE, Protective earth conductor

Note: Set value and supply voltage must be galvanically isolated.

OPEN / CLOSE version (relay version) (Code 00)

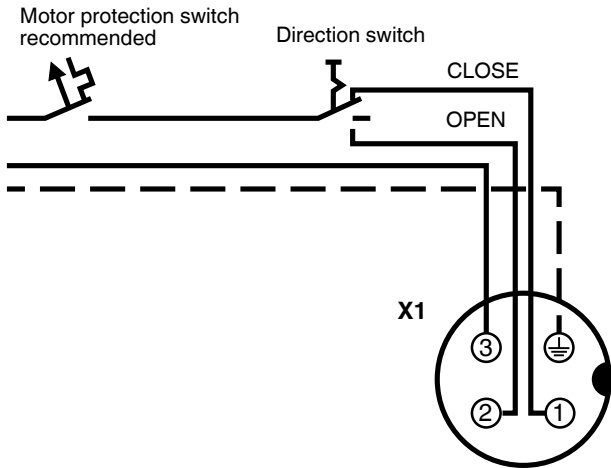

Pin	Signal name
1	L1, Direction of travel CLOSE
2	L1, Direction of travel OPEN
3	N, Neutral conductor
Ⓧ	PE, Protective earth conductor

2 potential-free limit switches (relay version) (Code 0E)

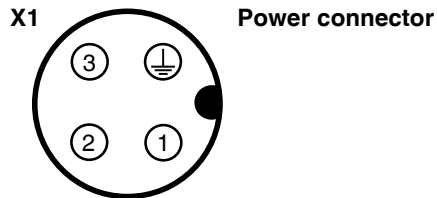

Pin	Signal name
1	L1, Direction of travel CLOSE
2	L1, Direction of travel OPEN
3	N, Neutral conductor
Ⓧ	PE, Protective earth conductor

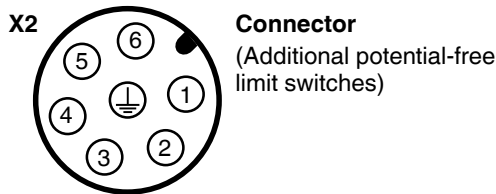

Pin	Signal name
1	Change-over contact limit switch CLOSE
2	Make-contact limit switch CLOSE
3	Break-contact limit switch CLOSE
4	Break-contact limit switch OPEN
5	Make-contact limit switch OPEN
6	Change-over contact limit switch OPEN
Ⓧ	PE, Protective earth conductor

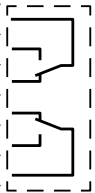

Potentiometer output (relay version) (Code 0P)

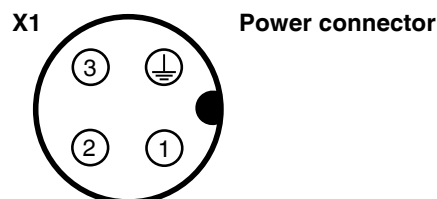

Pin	Signal name
1	L1, Direction of travel CLOSE
2	L1, Direction of travel OPEN
3	N, Neutral conductor
Ⓧ	PE, Protective earth conductor

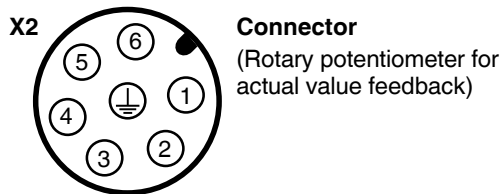

Pin	Signal name
1	n.c.
2	n.c.
3	n.c.
4	Us-, Actual value potentiometer signal voltage minus
5	Us, Actual value potentiometer signal output
6	Us+, Actual value potentiometer signal voltage plus
Ⓧ	PE, Protective earth conductor

For further actuators and other products, please see our Product Range catalogue and Price List.
Contact GEMÜ.